

AMCS-S-0x-B/BL



Product Description

AMCS® [pronounced. a-maks] (Advanced Motion Control Server) is an advanced server designated to control both brush and brushless DC servomotors with phase commutation. The user can designate which axes are brushed and which are brushless. It features much more than a typical stand-alone motion controller with network connectivity.

AMCS is a full-featured web server with an embedded multi-axis motion controller in a very compact enclosure. It provides tremendous capabilities in network communication, including the Internet, and at the same time functions independently through its own system software. The server can be accessed either through a HTML graphical interface or client applications. Devices incorporating the AMCS can be controlled and monitored from any place on the globe through the worldwide computer network. The controller is ideal for many automation applications, such as robotic, machine tools, semiconductor, scientific, medical, packaging, textile and industrial.

AMCS works in the Client-Server network architecture with the additional possibility of creating local sub-networks, in case of a bigger number of control devices. In the latter case, the controllers work in a hierarchical Server-Agent configuration. The server, unlike the agent, has the system software with more features and supervises a group of agents. Both, the server and the agent are capable of directly controlling motor drives.

The motion controller harnesses the power of DSP and ASIC chips to implement the motion control algorithms. It incorporates the advanced PID filter with velocity and acceleration feedforward, bias offset and 32-bit position error. The trajectory generator can create S-curve, trapezoidal, velocity contouring or electronic gearing motion profiles. The axes can be programmed independently or synchronously and can operate in open or closed servo loop modes. Motion functions support among others coordinated linear and circular interpolation, point-to-point positioning and contouring, backlash compensation, jog-

ging and homing procedures.

Embedded Program Manager supervises all control programs. It provides a multi-tasking environment for parallel programs execution, stopping and resuming. It also provides information about currently loaded and running programs. The file system enables data and parameters persistence.

AMCS is supported by the e-NetMotion™ and EasyMotion™ programs written in Java. The e-NetMotion client application is a graphical interface allowing the server and agents structure management, user account administration and facilitating access to the control devices depending on the user privilege level. Additionally, it provides a secure access to the system, secure transfer of data, programs and commands, and also remote monitoring of the current status of all controllers in the network.

The EasyMotion graphical user interface assists in a quick and easy way to set up and tune even complex electro-mechanical systems.

The controller is programmed by commonly used languages and therefore does not require an advance level of programming knowledge. Embedded interpreters make possible writing control programs in G-code and HPGL standards, C language and a language used in controllers from the Galil company. They permit programming of advanced motion trajectories realized by various kinematical configurations.

The open software-hardware architecture allows for very easy system customization. Optionally, the controller can be equipped with additional I/Os, wireless network communication and integrated drives for brush type DC servomotors.

Server features:

- Communication channels: 10/100 Mbps Base-T Ethernet port, and RS-232 and RS-485 serial ports
- Hierarchical Client-Server-Agent configuration simplifying the network structure of control devices
- Secure file transfer protocol (SFTP or SCP) for file and program transfers
- Logging to the server, data and command transfer using XML-RPC protocol
- The HTTP web server allowing GUI development with HTML
- Data transfer using the XML standard and the TCL interpreter
- Embedded mechanism of devices and user accounts administration
- Multi-tasking Program Manager supervising control programs
- Remote monitoring of the current state of all controllers in the network
- The file system allowing for data and parameters persistence

Motion features:

- Uses DSP and ASIC high speed dedicated motion processors in 1, 2 or 4 axes configuration
- Supports single phase brush and 2 or 3- phase brushless motors
- 6-step (Hall based) or sinusoidal commutation of brushless motors only
- Independent or synchronous axes programming
- Open or closed servo loop operating modes
- Advanced PID filter with velocity and acceleration feedforward, bias offset and 32-bit position error
- Axis settled indicator and tracking window in addition to automatic motion error detection
- Choice of S-curve, trapezoidal, velocity contouring or electronic gearing motion profiles
- Asymmetric acceleration and deceleration to custom program a trapezoidal motion profile
- Velocity and acceleration changes on-the-fly for trapezoidal and velocity contouring profiles
- Position range from -2,147,483,648 to +2,147,483,647 counts
- Velocity range from -32,768 to +32,767 counts/sample with a resolution of 1/65,536 counts/sample in velocity contouring profile mode or from 0 to 32,767 counts/sample with a resolution of 1/65,536 counts/sample in all other modes
- Acceleration and deceleration range from -32,768 to 32,767 counts/sample² with a resolution of 1/65,536 counts/sample²
- Jerk range from 0 to 1 counts/sample³ with a resolution of 1/4,294,967,296 counts/sample³
- Electronic gear ratio range from -32,768 to 32,767 (negative and positive direction)
- Programmable sample rate from 150 μsec to 3355 msec per axis
- Single-ended or differential incremental encoder maximum rate up to 5.0 Mcounts/sec
- Maximum parallel feedback device rate up to 160.0 Mcounts/sec

- Parallel feedback device word size: 16 bits
- 3 Hall effect input signals per axis (TTL level) for brushless motors only
- Commutation rate 10 kHz for 4 axes or 20 kHz for 2 axes
- +/-10V 16-bit DAC differential or single-ended output signal
- PWM motor output signal of 10-bit resolution at 20 kHz - 50/50 PWM mode supports 1, 2 or 3 phase motors, Sign/Magnitude PWM mode supports 1 or 2 phase motors only
- 64 kByte dual-port memory buffer for real-time data and parameters storage
- Trace capabilities for system performance testing, servo-filter tuning and diagnostic purposes
- Motion functions support coordinated linear and circular interpolation, point-to-point positioning and contouring, backlash compensation, jogging, homing, etc.
- Status reporting for position, speed, errors and safety
- Programmable event triggers for monitoring elapsed time, motion complete, position, motion error, limit switches and position wrap-around

I/O features:

- Dedicated opto-isolated inputs for over-travel limits, home sensor, and motor drive enable and fault handshaking operating at +5V, +12V, +24V or +48V
- Opto-isolated dedicated outputs for amplifier enable signals
- 8 general purpose 10-bit analog inputs in range of 0 to 5.0V DC
- 8 general purpose discrete TTL level input lines expandable to 256 inputs
- 8 general purpose discrete output lines operating at TTL level, expandable to 128 outputs or paralalled by 8 opto-isolated signals capable of sinking or sourcing maximum 350mA at 50V

Safety features:

- Automatic motor shutdown on motion error
- Programmable watchdog timer in a range of 1 - 393 msec
- Programmable software reset
- Power supply voltage monitor circuit to reset the system
- External reset circuit

Software features:

- High level programming with G-code and HPGL, C language interpreter and a language used in controllers from the Galil company
- The e-NetMotion™ (GUI) Java application facilitating full access to any device in the network
- The EasyMotion™ (GUI) Java application assists in a quick and easy way to set up and tune even complex electro-mechanical systems

Options:

- Wireless communication
- Expanded number of motion axes
- Expanded number of I/Os

Axes Control Signals Connector (J1)

Pin	Signal Name	Pin	Signal Name	Pin	Signal Name	Pin	Signal Name
01	QuadA1+	26	QuadA2+	51	QuadA3+	76	QuadA4+
02	QuadA1-	27	QuadA2-	52	QuadA3-	77	QuadA4-
03	QuadB1+	28	QuadB2+	53	QuadB3+	78	QuadB4+
04	QuadB1-	29	QuadB2-	54	QuadB3-	79	QuadB4-
05	Index1+	30	Index2+	55	Index3+	80	Index4+
06	Index1-	31	Index2-	56	Index3-	81	Index4-
07	Vcc (encoder)	32	Vcc (encoder)	57	Vcc (encoder)	82	Vcc (encoder)
08	GND (encoder)	33	GND (encoder)	58	GND (encoder)	83	GND (encoder)
09	Hall1A*	34	Hall2A*	59	Hall3A*	84	Hall4A*
10	Hall1B*	35	Hall2B*	60	Hall3B*	85	Hall4B*
11	Hall1C*	36	Hall2C*	61	Hall3C*	86	Hall4C*
12	GND (Hall)	37	GND (Hall)	62	GND (Hall)	87	GND (Hall)
13	PosLim1	38	PosLim2	63	PosLim3	88	PosLim4
14	NegLim1	39	NegLim2	64	NegLim3	89	NegLim4
15	Home1	40	Home2	65	Home3	90	Home4
16	AxisIn1	41	AxisIn2	66	AxisIn3	91	AxisIn4
17	AxisOut1	42	AxisOut2	67	AxisOut3	92	AxisOut4
18	PWMMagA1	43	PWMMagA2	68	PWMMagA3	93	PWMMagA4
19	PWMMagB1*	44	PWMMagB2*	69	PWMMagB3*	94	PWMMagB4*
20	PWMMagC1*	45	PWMMagC2*	70	PWMMagC3*	95	PWMMagC4*
21	Not used	46	Not used	71	Not used	99	Not used
22	DACA1	47	DACA2	72	DACA3	97	DACA4
23	DACB1*	48	DACB2*	73	DACB3*	98	DACB4*
24	GND (DAC)	49	GND (DAC)	74	GND (DAC)	99	GND (DAC)
25	OPTO GND	50	OPTO GND	75	OPTO GND	100	OPTO GND

* - depends on user axes designation

Miscellaneous I/O Connector (J2)

Pin	Signal Name	Pin	Signal Name	Pin	Signal Name	Pin	Signal Name
01	PrIn0	12	PrOut3	23	High PrOut6	34	AnalogRefLow
02	PrIn1	13	PrOut4	24	High PrOut7	35	AnalogVcc
03	PrIn2	14	PrOut5	25	AnalogIn0	36	AnalogGND
04	PrIn3	15	PrOut6	26	AnalogIn1	37	Amp Enable0
05	PrIn4	16	PrOut7	27	AnalogIn2	38	Amp Enable1
06	PrIn5PrOut2	17	High PrOut0	28	AnalogIn3	39	Amp Enable2
07	PrIn6	18	High PrOut1	29	AnalogIn4	40	Amp Enable3
08	PrIn7PrOut3	19	High PrOut2	30	AnalogIn5	41	Amp +VS
09	PrOut0	20	High PrOut3	31	AnalogIn6	42	Amp GND
10	PrOut1	21	High PrOut4	32	AnalogIn7	43	Reset Out
11	PrOut2	22	High PrOut5	33	AnalogRefHigh	44	Hstrdy

RS-485 (J3)

Pin	Signal Name
1	DCD
2	RXD
3	TXD
4	DTR
9	GND

RS-232 (J4)

Pin	Signal Name
1	DCD
2	RXD
3	TXD
4	DTR
9	GND

Ethernet (J5)

Pin	Signal Name
1	RTX+
2	RTX-
3	NRX+
6	NRX-

Power (J6)

Pin	Signal Name
1	GND
2	-12V
3	GND
4	+12V
5	+5V

Environmental and Electrical Ratings

Dimensions	5.125" x 4.5" x 1.875" (130mm x 114mm x 48mm)
Storage Temperature	-40 °C to 125 °C
Operating Temperature	0 °C to 70 °C (an industrial version with an operating range of -40 °C to 85 °C is also available)
Power Consumption	2.5A @ 5V; 40mA @ -12V; 50mA @ +12V
Supply Voltage Limits	-0.3V to +7.0V; -15.0 to +15.0V
Supply Voltage Operating Range	4.75V to 5.25V; -10.0V to -15.0V; +10.0V to +15.0V
Analog Output Range	-10.0V to 10.0V
Analog Input Range	0.0V to 5.0V

Ordering information

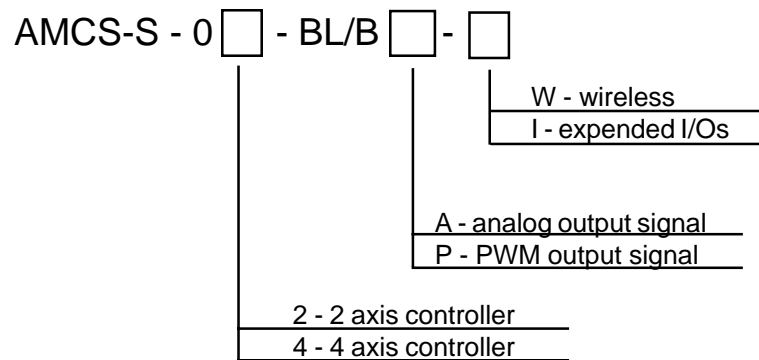

Contact information:

For additional information please visit <http://www.citosys.com> e-mail: info@citosys.com

Cito
Systems